

U.S. DEPARTMENT OF ENERGY – BONNEVILLE POWER ADMINISTRATION (BPA)  
APPLICATION FOR PROPOSED USE OF BPA RIGHT-OF-WAY

**Privacy Act Statement:**

**Authority:** 42 USC § 7101 and 50 USC § 2401

**Purpose:** BPA will use this information to assess whether your proposed use of our right-of-way will interfere with BPA's land rights.

**Routine Uses:** This information is authorized to be maintained in Privacy Act system of records DOE-24, "Land Records System." Other routine uses for which this information may be disclosed are listed in the Privacy Act system of records notice for DOE-24, which is published in the Federal Register.

**Disclosure:** Voluntary; however, failure to provide complete information may result in a delay or denial of your application.

**INSTRUCTIONS:** Applicant is required to complete all of page 1 and 2. If not submitting an attached map, plan or sketch, page 3 is required.

**Payment must be made electronically.** To make a payment go to: <https://www.bpa.gov/goto/HowtoPay>: Select "BPA online payments" hyperlink. In the form please fill in all the required fields. Under Purpose of Payment select REALTY APPLICATION FEE. Please make sure to select the appropriate box below before making your payment. You should receive a confirmation when finished.

**No Application Fee:** For individual landowners requesting personal use of BPA Right-of-Way.

**\$250 Application Fee:** For developments or subdivisions. Application fee is non-refundable.

**\$2500 Application Fee:** For longitudinal occupancies that require multiple miles of BPA Right-of-Way. Application fee is non-refundable.

Ask for Real Property Services at : 1-800-282-3713/[www.bpa.gov/goto/LandsCommunity](http://www.bpa.gov/goto/LandsCommunity)

1. Date \_\_\_\_\_

2. Applicant Information:

Applicant Name \_\_\_\_\_ Phone Number \_\_\_\_\_ Fax Number \_\_\_\_\_

Address: Street \_\_\_\_\_ City \_\_\_\_\_ State \_\_\_\_\_

ZIP Code \_\_\_\_\_ Email Address \_\_\_\_\_

3. Owner Information (Complete only if the applicant is not the owner):

Owner Name \_\_\_\_\_ Phone Number \_\_\_\_\_ Fax Number \_\_\_\_\_

Address: Street \_\_\_\_\_ City \_\_\_\_\_ State \_\_\_\_\_

ZIP Code \_\_\_\_\_ Email Address \_\_\_\_\_

4. Legal description of the property (This information is on your title, insurance policy, courthouse deed, or your tax statement.)

**Note:** Applicant must provide a county assessor's map showing the owner's boundary lines and the location of use.

Location Of Property:

Quarter Section(s)      Section(s)      Township      Range      County      State

\_\_\_\_\_

### APPLICATION FOR PROPOSED USE OF BPA RIGHT-OF-WAY

5. Purpose For Which BPA Right-Of-Way/Property Is To Be Used. Check all boxes that apply and complete the information on the following page. (Include a map, plan or sketch if appropriate.)

**NOTE:** For submission of digital plans please provide a PDF version. BPA will request larger plans, if needed.

Driveway/Roadway Width (**Note:** Please attach existing and proposed grading plans)

Width \_\_\_\_\_ Material \_\_\_\_\_

Electric Service Line

Voltage \_\_\_\_\_ Underground \_\_\_\_\_ Overhead \_\_\_\_\_

Pipelines	Type:	Gas	Sewer	Water
	Diameter	_____	_____	_____
	Material	_____	_____	_____
	Buried Depth	_____	_____	_____

Customer Interconnection Request Number (*for interconnection requests only*) \_\_\_\_\_

Other Uses: Please describe your intended use in detail. In order to assure safe clearance, please describe any equipment that will be used for applied use (*including equipment intended to construct and maintain the use*). Space is provided on page 3 for a drawing. If grading, please attach existing and proposed grading plans.

6. Applicant Name \_\_\_\_\_ 7. Applicant Title \_\_\_\_\_

8. Applicant Signature \_\_\_\_\_

9. Right-Of-Way: Draw in space provided below the location of the proposed use (*Identify structures and show distances and angles from BPA structures*). Diamonds on the line represent BPA structures on the right-of-way. Copy the series of letters and numbers from the lower half of each BPA structure (*see example below*) and enter in “BPA Structure Identification” block. Indicate which direction is “North” in relation to the right-of-way.

**BIG E – CHEM 1-81-2**  
BPA Structure Identification



**PS2 1-2-A**  
BPA Structure Identification



Identify structures and show distances and angles from BPA structures.

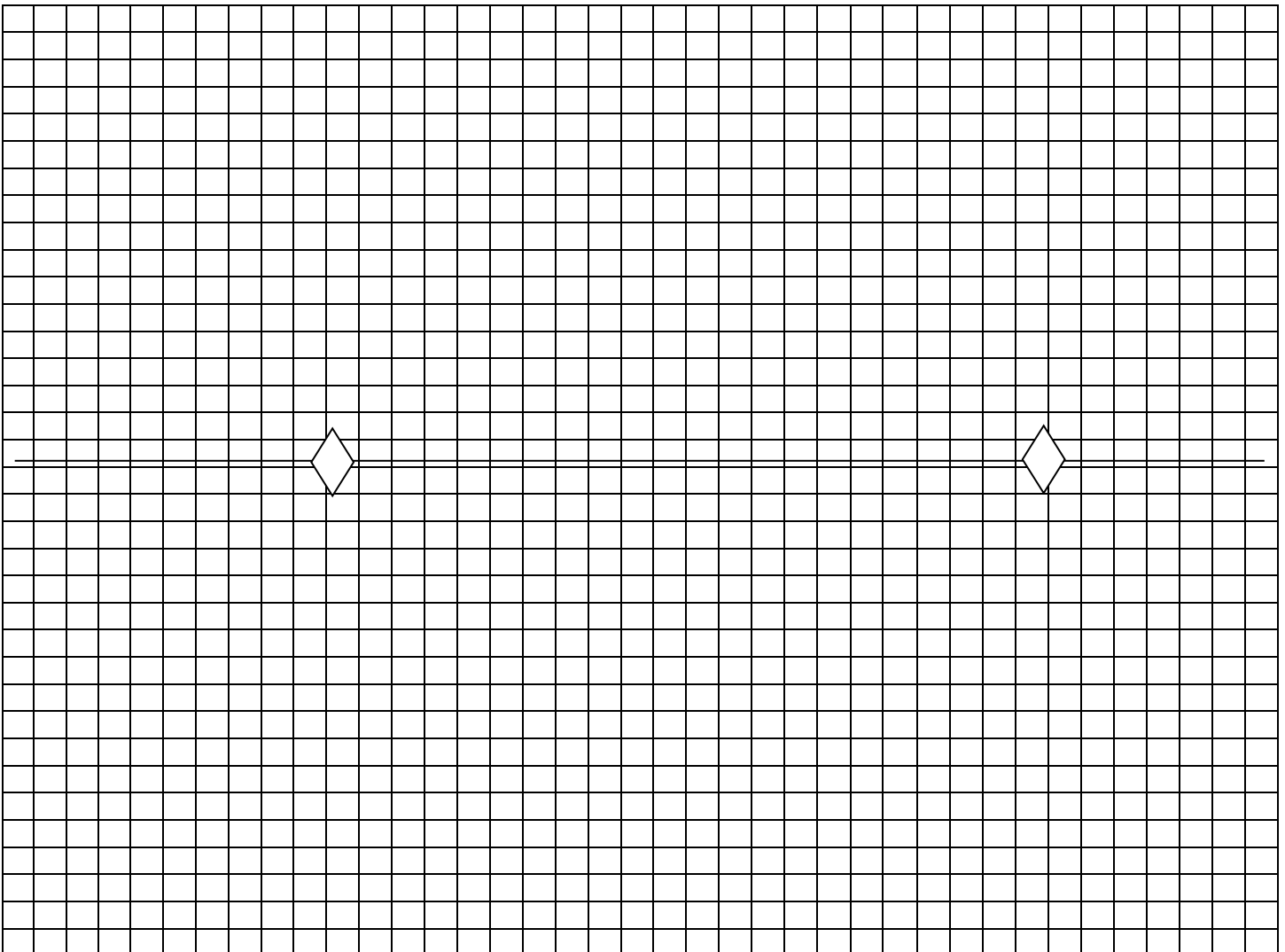

BPA Structure Identification \_\_\_\_\_

BPA Structure Identification \_\_\_\_\_

**APPLICATION FOR PROPOSED USE OF BPA RIGHT-OF-WAY**

Applicant Name \_\_\_\_\_

Complete **ONLY** if overhead or underground foreign line crosses an overhead BPA line. If the foreign line crosses more than one BPA line use additional sheets

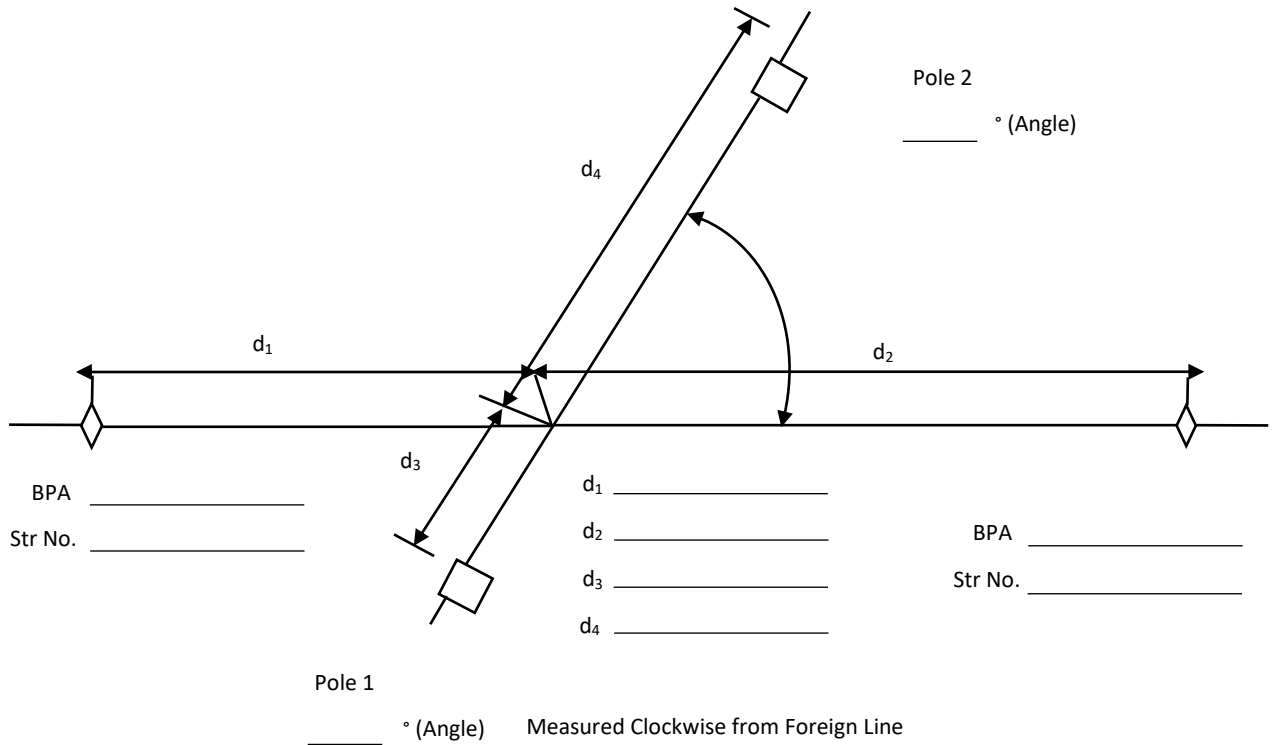

**PLAN**

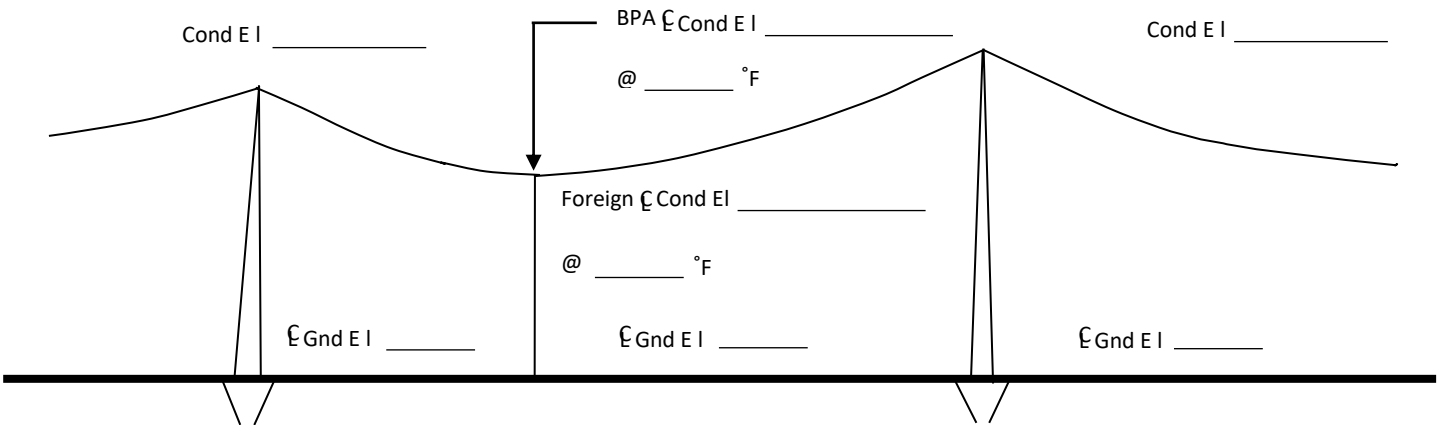

**APPLICATION FOR PROPOSED USE OF BPA RIGHT-OF-WAY**

Applicant Name \_\_\_\_\_

**Elevation BPA line**

Poles	Length	Depth Set	Class Pole
Pole 1			
Pole 2			

**Fixtures**

Size of Crossarms \_\_\_\_\_

Make & Catalog Number Of Insulators:

**Conductors**

Number	_____	Size	_____
Kind	_____	Voltage	_____
MWT	_____	Loading	_____

Comments:

Pole 1 Configurations \_\_\_\_\_

Pole 2 Configurations \_\_\_\_\_

**APPLICATION FOR PROPOSED USE OF BPA RIGHT-OF-WAY**

Mail your application to the location nearest to your project:

**WESTERN WASHINGTON**

<b>Location and Address</b>	<b>Phone Number</b>
Snohomish District Office, 914 Ave D, Snohomish, WA 98290	360-563-3640
Covington District Office, PO Box 3621, Portland, OR 97208-3621	253-638-3741
Olympia District Office, 5240 Trosper St SW, Olympia, WA 98512	360-570-4352, 360-570-4333 OR 360-570-4332
Ross Maint. Hdqt. Office, PO Box 3621, Portland, OR 97208-3621	800-836-6691

**OREGON**

<b>Location and Address</b>	<b>Phone Number</b>
Redmond District Office, 3655 SW Highland Ave., Redmond, OR 97756	541-516-3200
Eugene District Office, 86000 Hwy 99S, Eugene, OR 97405	541-988-7432
Salem District Office, 2715 Tepper Lane, Keizer, OR 97303	503-304-5900
Portland Office, PO Box 3621, Portland, OR 97208-3621	800-836-6619
Hood River, <i>(see Portland for mailing address)</i>	
North Bend Area, <i>(see Portland for mailing address)</i>	

**EASTERN WASHINGTON, IDAHO AND MONTANA**

<b>Location and Address</b>	<b>Phone Number</b>
Idaho Falls District Office, <i>(see Tri-Cities Pasco, WA mailing address)</i>	509-544-4747
Tri-Cities District Office, <i>(OR Side)</i> , 2211 North Commercial Avenue, Pasco, WA 99301	509-544-4747
Tri-Cities <i>(WA side)</i> , 2211 North Commercial Avenue, Pasco, WA 99301	503-230-5510
Spokane District Office, 2410 E. Hawthorne Rd., Mead, WA 99021-9594	509-468-3081
Grand Coulee Area, PO Box 24, Grand Coulee, WA 99133	509-378-7447
Ellensburg Area, PO Box 3621, Portland, OR 97208-3621	503-230-5611
Kalispell Maintenance District Office, 2520 US Hwy 2 East, Kalispell, MT 59901	406-751-7824